



Compila e invia il modulo per individuare il gruppo Frizione/Freno più adatto
Fill out and send this form to find out the best suited Clutch/Brake unit

Inviare /Send to: info@ompisrl.com

1

MISURA / SIZE

HT _ _ _ _

2

SELEZIONARE FRIZIONE-FRENO / SELECT CLUTCH-BRAKE

TT

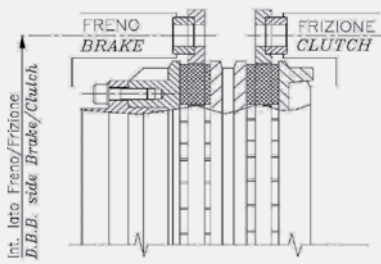

CC

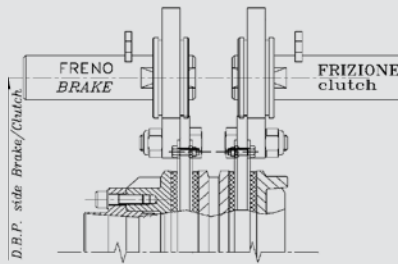

CS

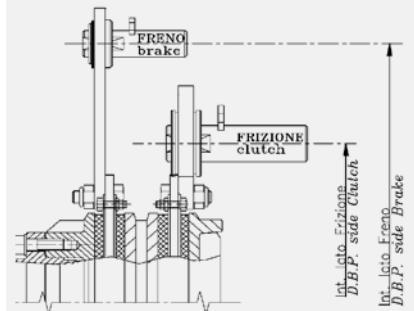

BB

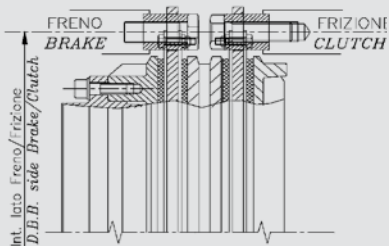

CB

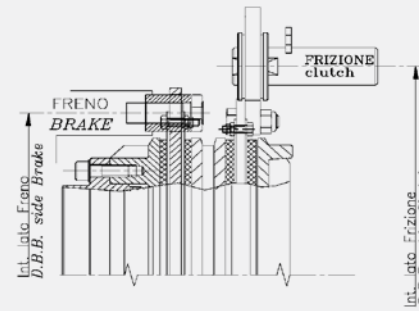

BC

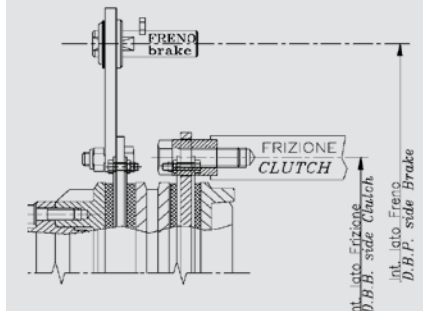

3

INTERASSI / D.B.P CLUTCH-BRAKE

Interasse frizione
D.B.B clutch

∅ _____ mm

Interasse freno
D.B.P. brake

∅ _____ mm

Interasse frizione/freno
D.B.P clutch/brake

∅ _____ mm

Angolo interasse freno
Degree D.B.P. brake

180° 160° 150°

4

SELEZIONARE INGRESSO ARIA DI COMANDO / SELECT PROPER INLET SERVICE AIR

Ingresso aria dall'albero
Inlet air on the shaft

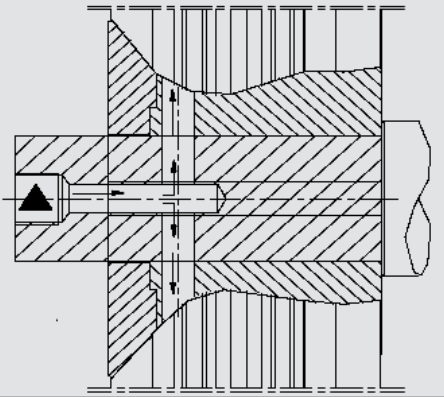

▲ Aria di comando / Drive Air

Ingresso aria dalla flangia
Inlet air on the flange

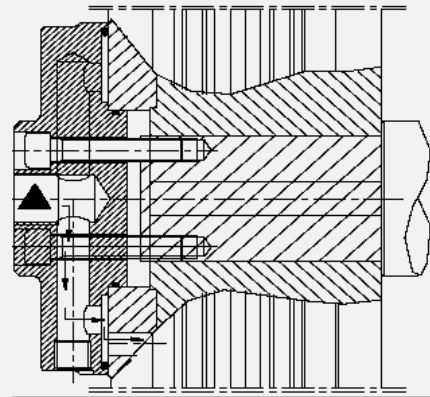

▲ Aria di comando / Drive Air

5

SELEZIONARE FORO / SELECT BORE

Foro con chiavetta
Bore with keyway

- 1 foro / 1 bore
- 2 fori / 2 bores

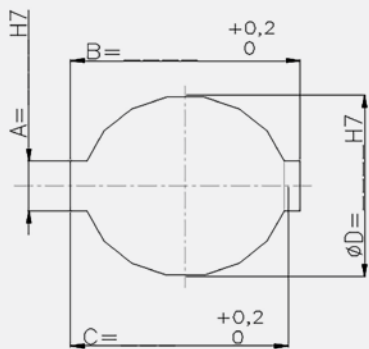

Quota "C" solo in caso di chiavetta singola
Quote "C" just one Keyway

Foro con calettatore
Bore with Locking Device

- Calettatore interno - Lato Freno
Internal Locking Device - Brake side
- Calettatore interno - Lato Frizione
Internal Locking Device - Clutch side
- Calettatore esterno - Lato Freno
External Locking Device - Brake side

Ø Interno / Intern

— — — — mm

Ø Esterno / External

— — — — mm

6

CLIENTE / COSTUMER

Cliente / Customer

Data / Date

/ /

dd mm dd

Indirizzo / Address



Via Piemonte 14 - 20841
Carate Brianza MB - Italia



+39 0362.91.22.20
+39 0362.99.32.04



www.ompisrl.com
info@ompisrl.com